



Epic Power Converters, S.L.
CIF: B99349623

Calle F Oeste, Nave 93. Grupo Quejido
Polígono Malpica - 50016 - Zaragoza (Spain)
info@epicpower.es - www.epicpower.es

Author
support@epicpower.es

AN023
This document gathers and summarizes the points connection to the DC link/bus of the most typically VVFs

Version
V1.3
June, 2020

Application Note - AN023

Connection to DC link of different VVVF drives

Introduction

This document gathers and summarizes the points connection to the DC link/bus of the most typically found drives/inverters found in Europe in lift and industrial applications. This document is designed to help find the right point of connection of epic power products but cannot be used alone as complete information for the installation.

The user will have to verify that the installation of the epic power products is done according to the installation manual paying especial attention to the procedure and safety recommendation.

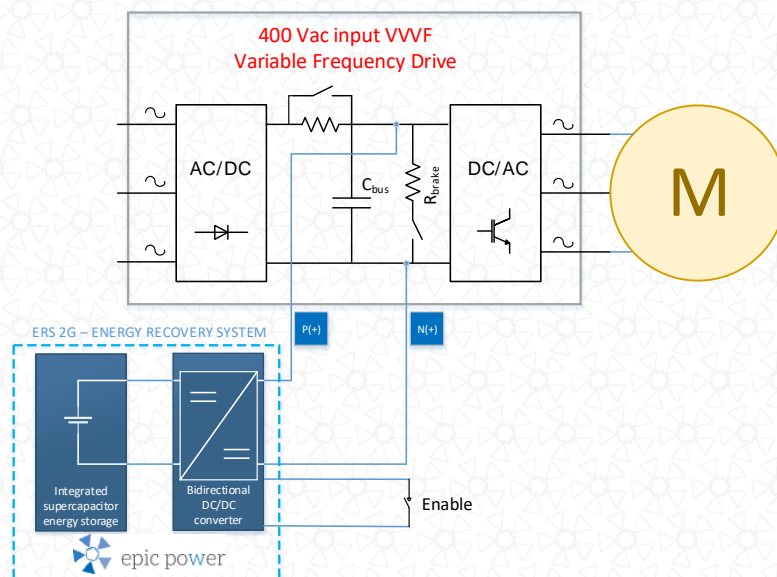

Table of DC Link connections depending on the drive manufacturer

In Table 1 different drive brands, their connections to the DC link (positive and negative) and a link to a schematic is depicted.

Drive brand	DC bus + (positive)	DC bus - (negative)	Figure
Control Techniques (Nidec)	DC+	DC-	Fig. 1
Fuji	P+	N-	Fig. 2
KEB	++	--	Fig. 3
Lenze	RB2	UG-	Fig. 4
Omron	P+	N-	Fig. 5
SEW	UZ+	UZ-	Fig. 6
Vacon	B+	B-	Fig. 7
Yaskawa	+1	-	Fig. 8
Ziehl Abbeg	+DC	-DC	Fig. 9
Danfoss	(+)	(-)	Fig. 10
epic power	P(+)	N(-)	

Table 1 - DC link terminals connections

Note: Do not forget to connect the earth (PE) terminals between epic power device and the drive



Control Techniques (Nidec) example

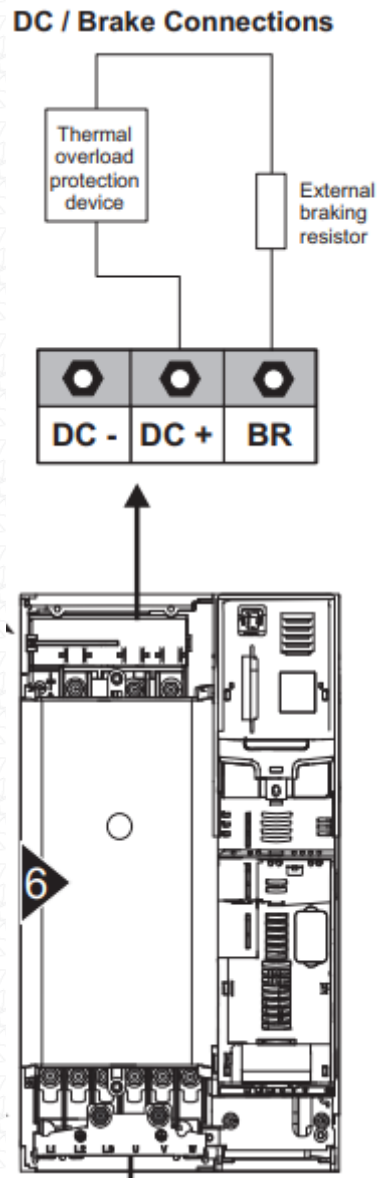

Fig. 1 - DC link connection to Nidec/Control Techniques



FUJI example

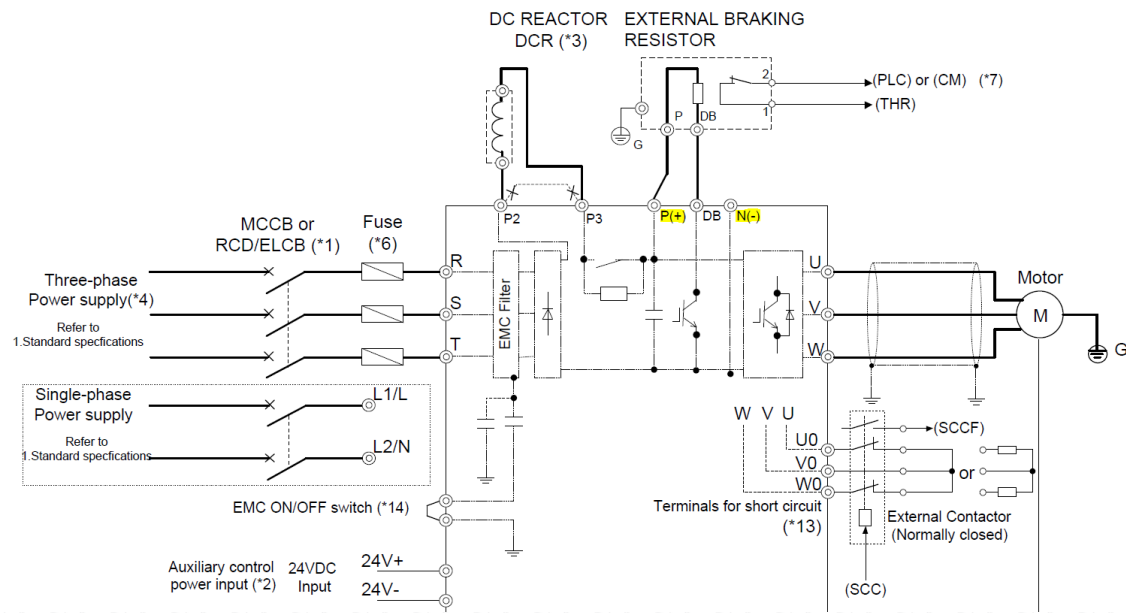

Fig. 2 - DC link connection to FUJI



KEB example

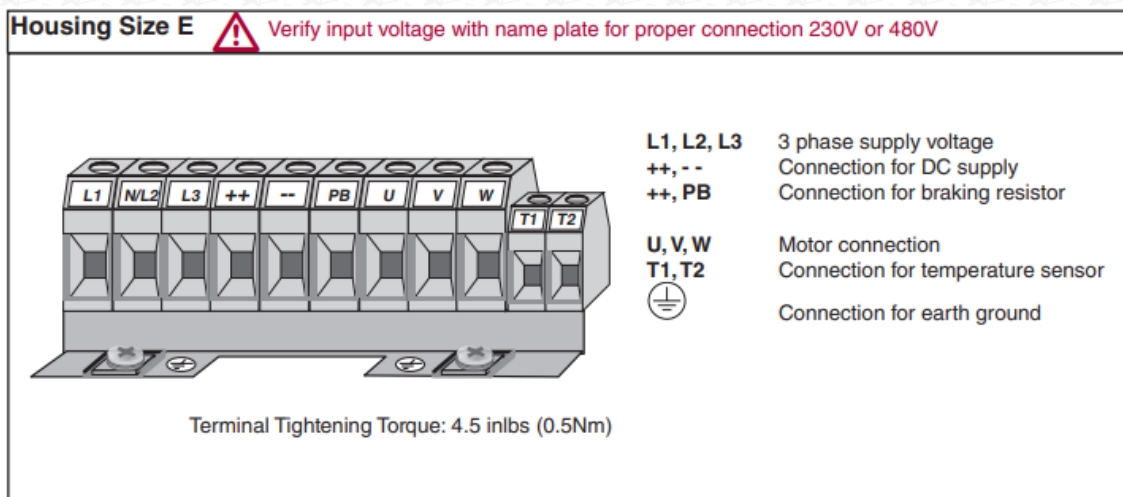

Fig. 3- DC link connection to KEB



LENZE example

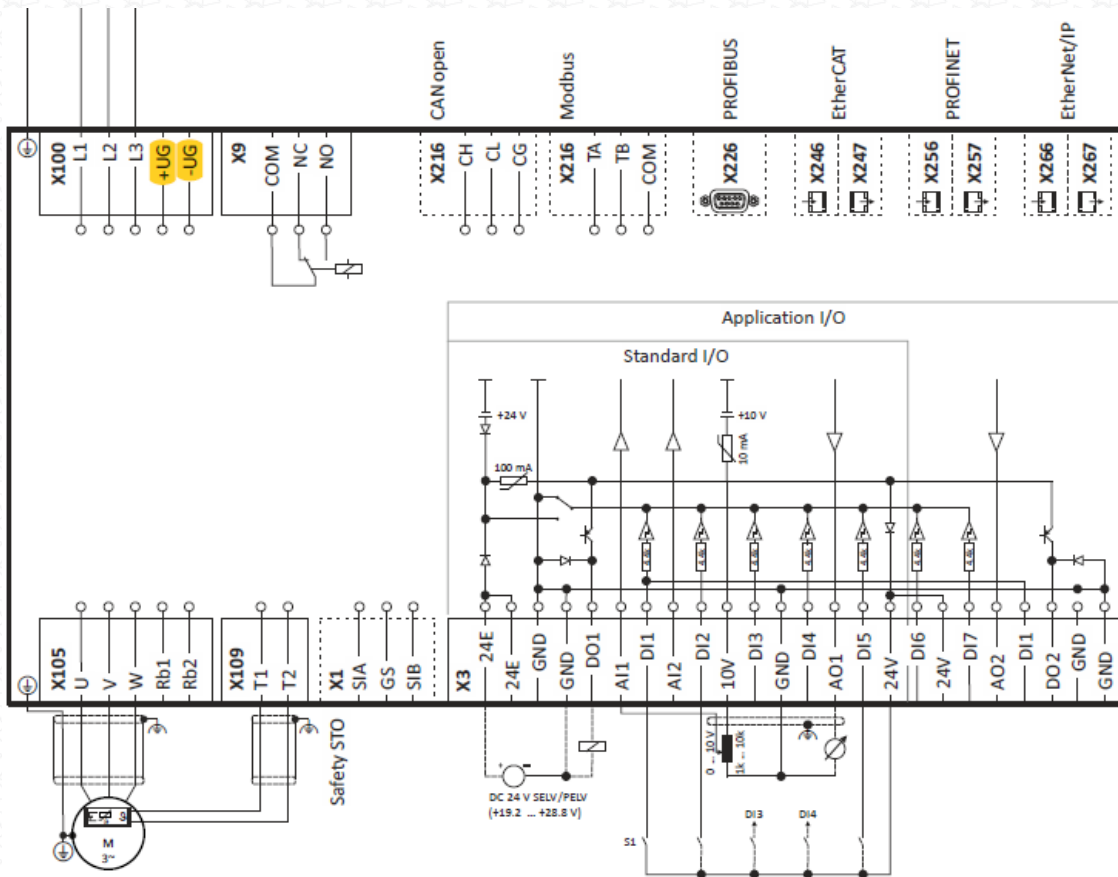

Fig. 4 - DC link connection to LENZE



OMRON example

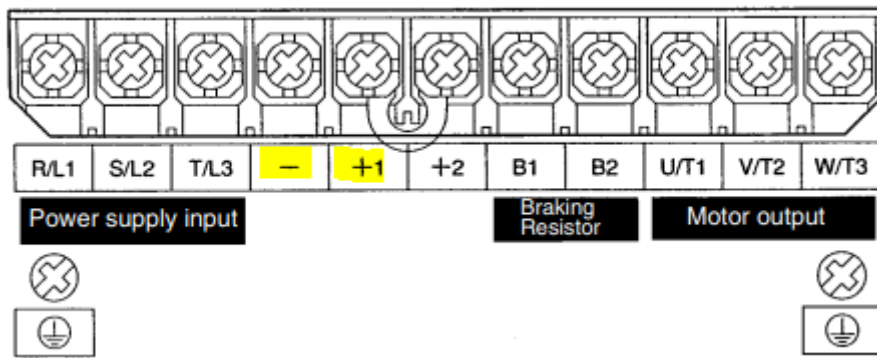
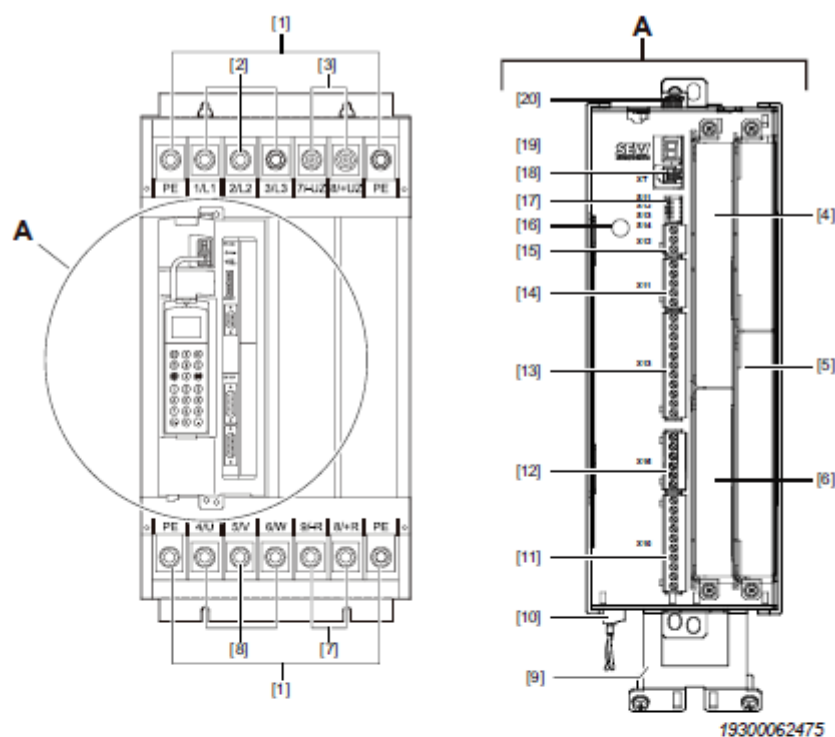

Fig. 5 - DC link connection to OMRON



SEW example



- [1] PE connection
- [2] X1: Line connection 1/L1, 2/L2, 3/L3
- [3] X4: Connection for DC link coupling $-U_z +U_z$
- [4] Fieldbus slot
- [5] Expansion slot
- [6] Encoder slot
- [7] X3: Braking resistor connection 8/+R, 9/-R
- [8] X2: Motor connection 4/U, 5/V, 6/W
- [9] Shield clamp for signal cables and PE connection
- [10] X17: Signal terminal block for safety contacts of drive safety function STO
- [11] X10: Signal terminal strip for digital outputs and TF/TH input
- [12] X16: Signal terminal strip digital inputs and outputs
- [13] X13: Signal terminal strip terminal strip for digital inputs and RS485 interface
- [14] X11: Signal terminal strip for setpoint input AI1 and 10 V reference voltage
- [15] X12: Signal terminal strip system bus (SBus)
- [16] Grounding screw M4 × 14
- [17] DIP switches S11 – S14
- [18] XT: Slot for DBG60B keypad or USB11A/UWS21B serial interface
- [19] 7-segment display

Fig. 6 - DC link connection to SEW



VACON example

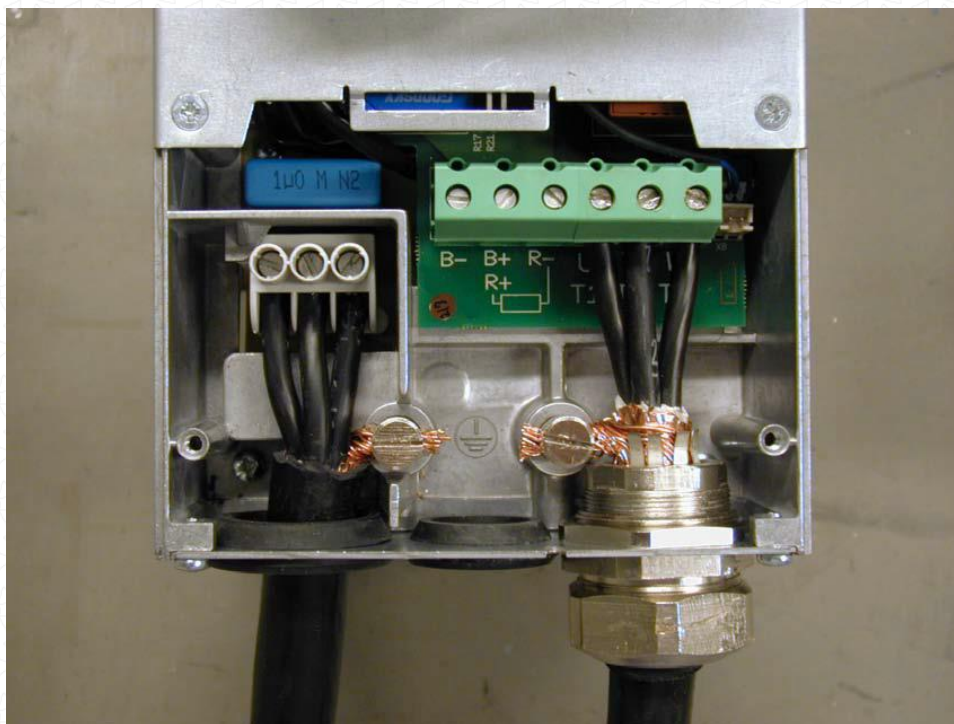

Fig. 7 - DC link connection to VACON



YASKAWA example

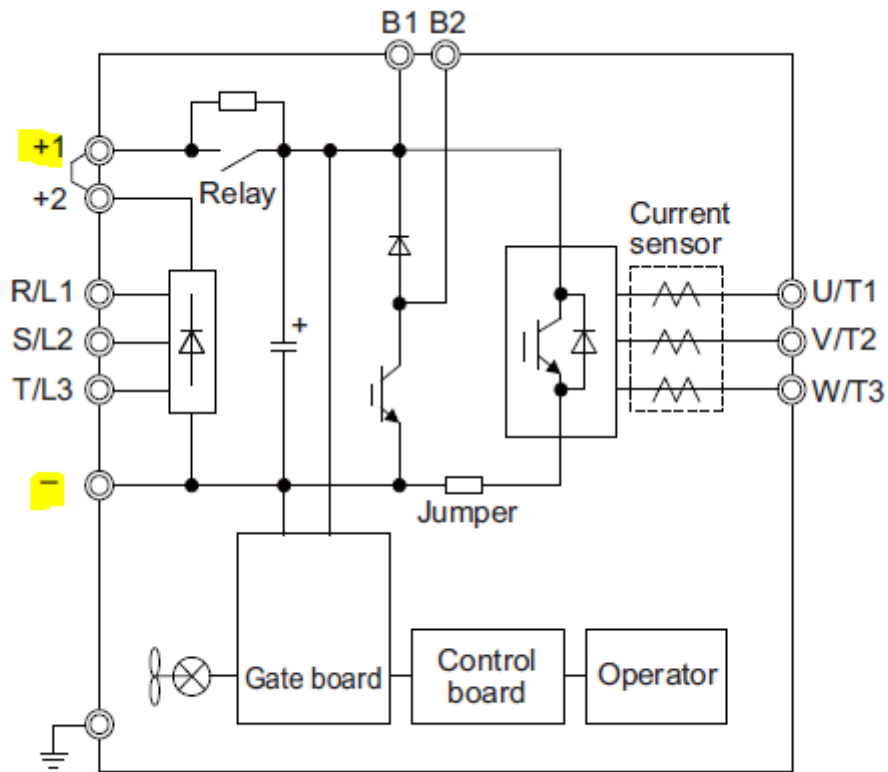

Fig. 8 - DC link connection to YASKAWA



Zielh Abbeg example

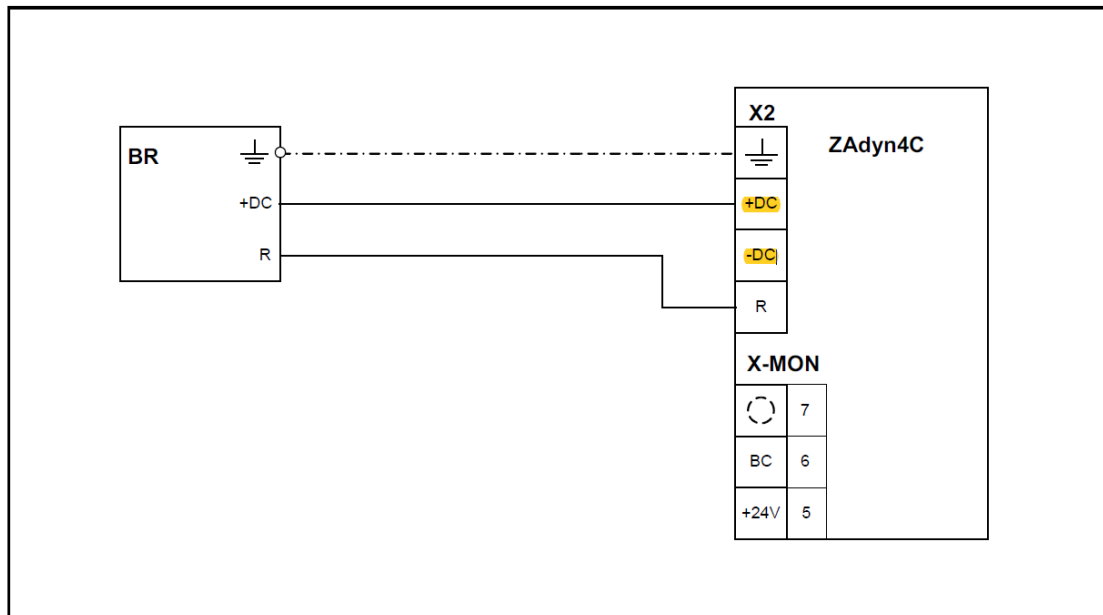

Fig. 9 - DC link connection to Zielh Abbeg



Danfoss example

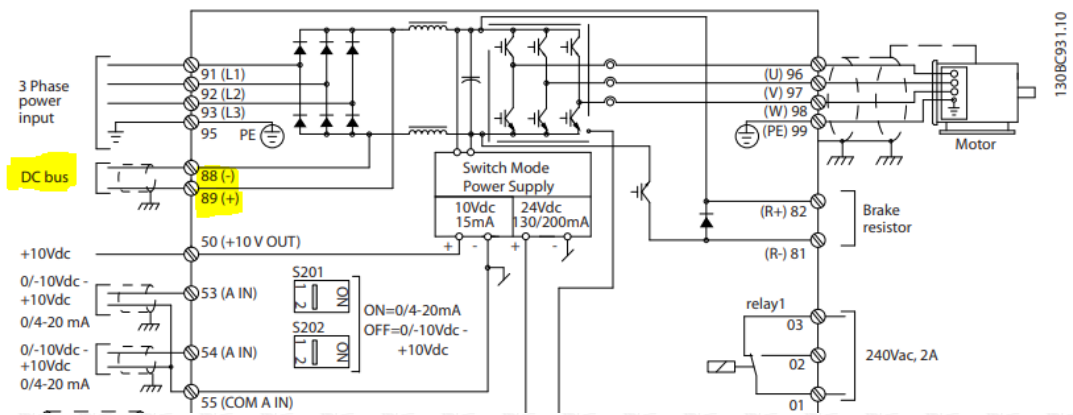

Fig. 10 - DC link connection to Danfoss

